



# M165913H.2

ITEM NUMBER: 165913

SERIAL NUMBER: \_\_\_\_\_

## Owner's Manual

### Instructions for Installation/Set-up, Operation, Servicing, & Storage

### Portable Outdoor Use-Only, Belt-Driven Generator

#### 5,000 Watt Continuous (5,500 Watt Surge) Capacity

Can be used to power individual appliances plugged directly into the generator's outlets, or as a back-up connection to a building's power supply (via a professionally installed UL-approved transfer switch).

### **⚠ WARNING**

**READ and UNDERSTAND this manual completely before using the generator!** Failure to properly set up, operate, and maintain this generator could result in *serious injury or death* from *carbon monoxide poisoning, electric shock, entanglement, fire, or burns*. In addition, an improperly secured generator *can lift or flip and cause severe injury*. In particular, be aware of the following hazards:

#### CO Poisoning

The running engine gives off carbon monoxide, a poisonous gas that can kill you. You CANNOT smell it, see it, or taste it.

- ONLY run generator-engine assembly OUTDOORS and AWAY from building air intakes. NEVER run inside any enclosed or semi-enclosed spaces, including homes, basements, garages, sheds, and boxes. These spaces can trap poisonous gases, EVEN if you run a fan or open windows.
- Install carbon monoxide alarms inside nearby structures/buildings (battery-operated, or plug-in with battery backup).

#### Electric shock / Electrocutation

- High voltage electricity from generator can kill. DO NOT operate in wet locations. Be sure generator is properly grounded. Use only UL-listed, outdoor-rated grounded GFCI-equipped extension cords of proper size.
- NEVER plug the generator directly into a wall outlet. ANY connection to a building's electrical system MUST ISOLATE THE GENERATOR FROM UTILITY POWER via a UL-approved transfer switch installed by a licensed electrician. Otherwise, back feed from the generator into the power grid could kill utility workers.

#### Fire

- DO NOT overload generator (per rated capacity), and OPERATE ONLY in an area with adequate cooling ventilation so generator does not overheat and possibly cause fire. Keep all objects at least 7' from generator vent openings. Refer to engine owner's manual for minimum safe clearance distance between hot engine exhaust and nearby combustible materials/structures.
- ALWAYS keep a fire extinguisher rated "ABC" nearby.

#### Entanglement / Moving Object Impact

- Never operate the generator without proper guarding of the power transmission assembly, including all rotating shafts, pulleys, belts, and couplings. Clothing or hair can become rapidly entangled in unguarded rotating parts, resulting in *serious injury or death*.
- Failure to properly mount and secure the generator may cause the unit to lift or flip during use, which could result in severe injury to the operator or bystanders, or cause damage to surrounding objects.

*Also see "Summary of Important Safety Information" in this manual.*

### **STOP!**

**CHOOSE THE RIGHT GENERATOR FOR YOUR NEEDS.** See the "Power load Planning & Management" section of this manual to determine your power load requirements and then compare to the generator's rated capacity.

**INSPECT COMPONENTS:** Closely inspect to make sure no components are missing or damaged. See the "Unpacking & Delivery Inspection" section for instructions on whom to contact to report missing or damaged parts.

**ENGINE and MOUNTING REQUIRED.** You will need to supply an engine to power this generator. The generator and engine must be mounted to a common base such as a heavy-duty metal plate. See the "Specifications", "About Your Generator", and "Installation/Initial Set-Up" sections of this manual for more information on these requirements.

**ARRANGE FOR PROFESSIONAL INSTALLATION of a transfer switch if you will be connecting the generator to your building's electrical system.** See the "Installation/Initial Set-Up" section for more information about this requirement.

**Any Questions, Comments, Problems, or Parts Orders**

***Call NorthStar Product Support 1-800-270-0810***

## Hazard Signal Word Definitions





	<p>This is the safety alert symbol. It is used to alert you to potential personal injury hazards. Obey all safety messages that follow this symbol to avoid possible injury or death.</p>
	<p>DANGER (red) indicates an imminently hazardous situation which, if not avoided, will result in death or serious injury.</p>
	<p>WARNING (orange) indicates a potentially hazardous situation which, if not avoided, could result in death or serious injury.</p>
	<p>CAUTION (yellow) indicates a potentially hazardous situation which, if not avoided, may result in minor or moderate injury.</p>
	<p>CAUTION (yellow) used without the safety alert symbol indicates a potentially hazardous situation which, if not avoided, may result in property damage.</p>

fig01453

# Table of Contents

<b>Hazard Signal Word Definitions</b> .....	2
<b>About Your Generator</b> .....	4
<b>Specifications</b> .....	6
<b>Safety Label Locations</b> .....	7
<b>Machine Component Identification</b> .....	8
<b>Power Load Planning &amp; Management</b> .....	10
<b>Installation / Initial Set-Up:</b>	
1. Unpacking & Delivery Inspection .....	12
2. Planning the Power Load .....	12
3. Set-up as a PORTABLE or BUILDING BACK-UP Power Source .....	13
4. Selecting a Suitable Site .....	16
5. Mounting & Connecting Generator and Engine .....	18
6. Grounding the Generator .....	22
<b>Operation:</b>	
1. General Safety Rules for Operation .....	23
2. Preparing for Operation (Pre-start checklist) .....	25
3. Starting the Generator .....	28
4. Connecting Loads .....	29
5. Stopping .....	31
6. Storage & Exercise .....	31
<b>Maintenance &amp; Repair</b> .....	33
<b>Troubleshooting</b> .....	35
<b>Summary of Important Safety Information</b> .....	36
<b>Generator Exploded View</b> .....	40
<b>Wiring Diagram</b> .....	41
<b>Limited Warranty</b> .....	43

# About Your Generator

Thank you for purchasing your NorthStar belt-driven generator!

## About Your Generator

**This belt-driven, portable generator is designed to provide up to 5000 Watts of electrical power** (5,000 watts continuous, 5,500 watts surge). Powered by an external engine, this generator can supply power:

1. As a portable power source. You can plug appliances directly into the generator's electrical outlets.
2. As a back up, standby power source for a building. A licensed electrician can connect the generator to your building's electrical system via the installation of an **UL-approved transfer switch**. (See the "Installation & Initial Set-up" section of this manual to learn more about specific requirements and precautions relating to wiring the generator to your building's electrical system.)

**\* The engine you supply must be rated at 11 HP minimum.**

**You must select a generator adequately sized for your power needs.** You need to determine the power needs of all the appliances/tools you wish to power at the same time and choose a generator rated to provide at least that power level. See the "Power Load Planning & Management" section of this manual to determine your specific power load requirements and then compare them to this generator's rated capacity. You must not overload the generator. Overloading will cause damage to the generator and attached electrical devices, and may also result in fire.

**This generator and the engine must be mounted to a common base such as a heavy-duty metal plate.** Secure mounting will ensure that the generator will not lift or flip during use, and will also help prevent belt slippage. The mounting base must be of adequate size and strength to withstand operating torque and vibration without either flipping or experiencing stress failure. More detailed information about mounting can be found in the "Installation / Initial Set-Up" section of this manual.

**Be sure to read about site selection and grounding requirements for running this generator.** More detailed information can be found in the "Installation & Initial Set-up, Steps 5 & 6" of this manual.

**⚠ CAUTION:** This generator is too heavy for one person to lift without assistance.

Optional accessories available from NorthStar include UL-approved transfer switches and extension cords. **Contact NorthStar Product Support at 1-800-270-0810 with questions about optional accessories or to order.**

## Read this Manual

### **WARNING**

Improper use or maintenance of the generator can result in *serious injury or death* from *carbon monoxide poisoning, electric shock, entanglement, fire, or burns*. In addition, an improperly secured generator *can lift or flip and cause severe injury*.

**Read this manual completely** before using the generator and follow all instructions and safety rules.

## About Your Generator (cont'd)

You must follow all instructions and safety precautions presented throughout this manual. A summary of important safety information can be found at the end of the manual. Keep this manual for reference and review.

Proper preparation, operation, and maintenance will result in operator safety as well as best performance and long life of the generator. Failure to follow the instructions in this manual for proper mounting, set-up, operation, and maintenance of the generator will void the manufacturer's warranty.

Before using, the user shall determine the suitability of this product for its intended use and assumes liability therein. The purchaser and/or user shall assume liability for any modification and/or alterations of this equipment from original design and manufacture, or for any non-standard application, or for use as a subcomponent in another piece of equipment.

NorthStar is constantly improving its products. The specifications outlined herein are subject to change without prior notice or obligation.

**Contact NorthStar Product Support at 1-800-270-0810 for any questions about the appropriate use of this generator.**

### Warranty Registration

Please fill out and submit the warranty registration card so that we have your contact information for any future product literature or replacement parts you may need.

**ATTENTION:**  
**All Rental Companies and Private Owners who loan this equipment to others!**

*All persons to whom you rent/loan this generator must have access to and read this manual. Keep this owner's manual with the generator at all times and advise all persons who will operate the machine to read it. You must also provide personal instruction on how to safely operate the generator and remain available to answer any questions a renter/borrower might have.*

## Specifications – Item #165913

<b><i>SPECIFICATIONS</i></b>	
Item Number	165913
Maximum Output	5500 Watts (W)
Continuous Output	5000 Watts (W)
Voltage	120 / 240 Volt (V)
Phase	Single phase (4-wire)
Frequency	58.0 – 63.0 Hertz (Hz)
Power Factor	1.0 p.f.
Engine Minimum	11 hp
Engine Speed	3540-3720 RPM
Torque	16 ft-lbs
Drive Shaft	1.50" long, 3/16" keyway
120 V Receptacle	20 Amp (A) duplex (NEMA 5-20R)
240 V Receptacle	20 Amp (A) Locking Device (NEMA L6-20R)
Circuit Breaker	20 Amp (A) thermal, push to reset style
Dimensions	
Length	16.25" (413 cm)
Width	7.25" (184 cm)
Height	7.75" (197 cm)
Gross Weight	53 lb. (24.1 kg)

# Safety Label Locations – Item #165913





	<b>WARNING</b>
	<p style="text-align: center;"><b>HIGH VOLTAGE from generator can shock or kill.</b></p> <ul style="list-style-type: none"> <li>◆ NEVER connect generator directly into a wall outlet.</li> <li>◆ ANY connection to a building's electrical system <b>MUST ISOLATE GENERATOR FROM UTILITY POWER</b> via a transfer switch.</li> <li>◆ Be sure generator is properly grounded.</li> <li>◆ Use only outdoor rated grounded GFCI extension cords of proper size.</li> <li>◆ DO NOT operate in wet locations.</li> </ul>
	<p style="text-align: center;"><b>Clothing or hair can become rapidly ENTANGLED in unguarded rotating parts, resulting in serious injury or death.</b></p> <ul style="list-style-type: none"> <li>◆ ONLY operate with proper guarding of power transmission system, including all rotating sharfts, pulleys, belts &amp; couplings.</li> </ul>
	<p style="text-align: center;"><b>FIRE can result from:</b></p> <ul style="list-style-type: none"> <li>• Overloading the generator</li> <li>• Lack of cooling ventilation</li> <li>• Contact with hot engine exhaust</li> </ul> <ul style="list-style-type: none"> <li>◆ DO NOT overload generator</li> <li>◆ OPERATE ONLY with adequate cooling ventilation. Keep all objects at least 7 feet from generator vent openings.</li> <li>◆ Keep engine exhaust a safe distance away from all combustible objects.</li> <li>◆ ALWAYS keep a fire extinguisher nearby.</li> </ul>
	<p style="text-align: center;"><b>Generator may LIFT or FLIP during use if improperly mounted.</b></p> <ul style="list-style-type: none"> <li>◆ Generator and engine must be properly mounted to a common base.</li> </ul>
<p><b>Read Owner's Manual completely before using.</b> <span style="float: right;">NTE®</span></p>	

FIG02879



<p style="text-align: center;"><b>⚠ DANGER</b></p> <p style="text-align: center;">Using a generator indoors <b>CAN KILL YOU IN MINUTES.</b> Generator exhaust contains carbon monoxide. This is a poison you cannot see or smell.</p>	
 <p style="text-align: center;">NEVER use inside a home or garage. EVEN IF doors and windows are open.</p>	 <p style="text-align: center;">Only use <b>OUTSIDE</b> and far away from windows, doors, and vents.</p>
779407	

**Always make sure safety labels are in place and in good condition.** If a safety label is missing or not legible, order new labels or unsafe operation could result.

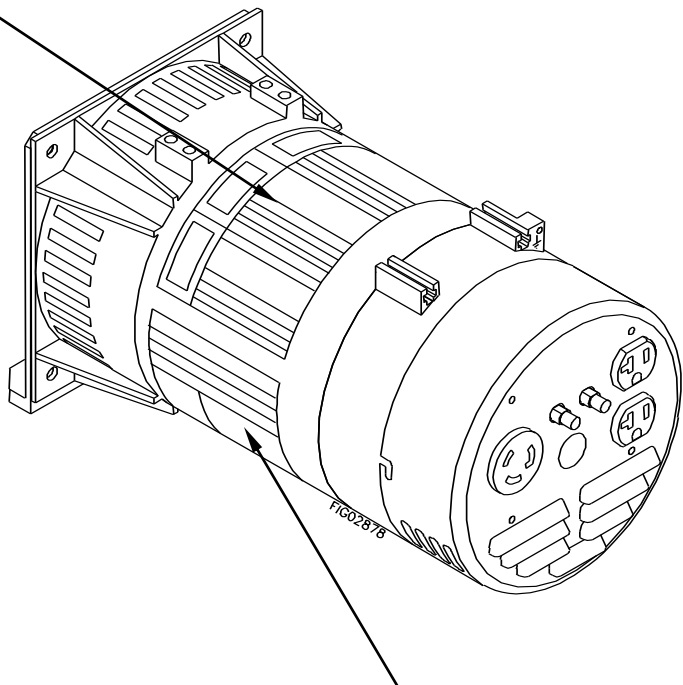
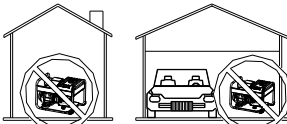
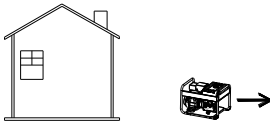
**To order replacement safety labels, call NorthStar Product Support at 1-800-270-0810.**

<b>On-Product Warning Labels</b>	
Part numbers	Description
779407	CPSC Warning
780342	General Warning

# Machine Component Identification - Item #165913H.1

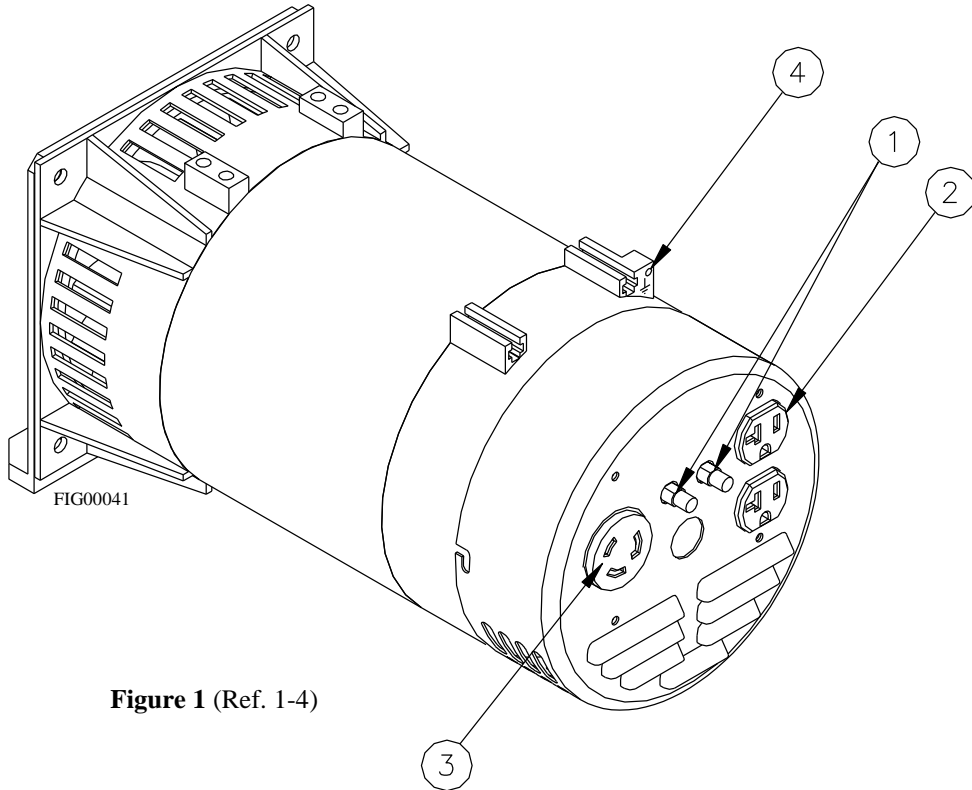

Figure 1 (Ref. 1-4)

Ref	Description	Ref	Description
1	Circuit Breakers	5	7/8" shaft
2	120V 20A Duplex Receptacle	6	Mounting feet
3	240V 20A Locking Receptacle	7	Fan vents
4	Grounding screw		

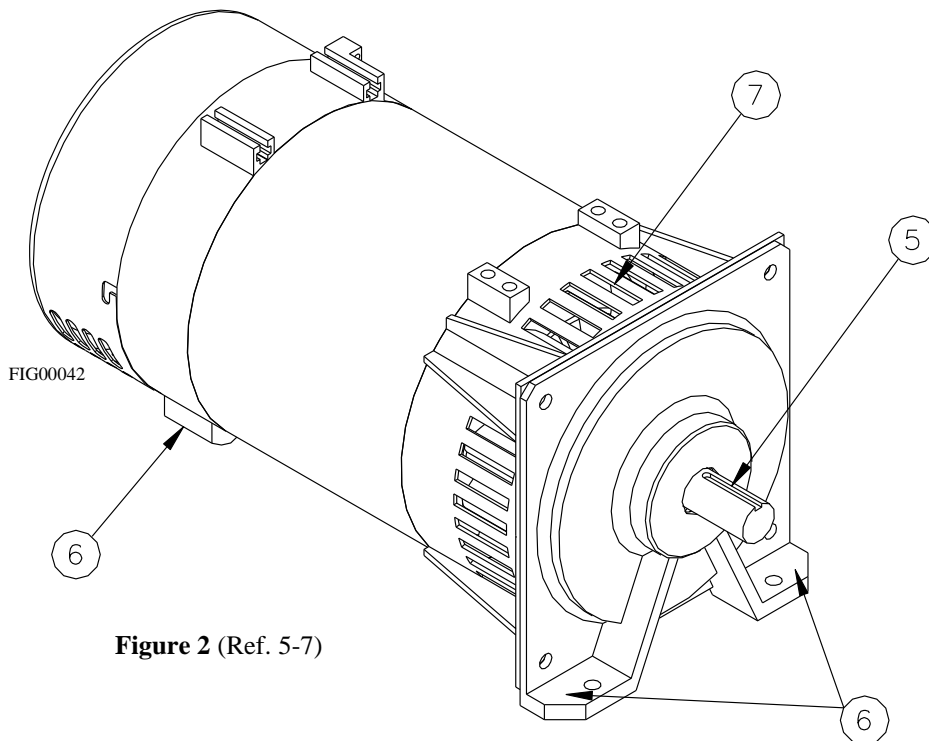

Figure 2 (Ref. 5-7)



## Machine Component Identification – Item #165913H.1 (cont'd)

<b><i>REFERENCE GUIDE</i></b>	
<b>Reference 1 – Circuit Breakers</b>	This belt driven single-phase generator has 2, 20 amp (A) push to reset circuit breakers to protect against electrical overloads.
<b>Reference 2 –120V Receptacle</b>	The generator has an end cover with one duplex (two receptacles in a common housing) receptacle and one locking device receptacle. The duplex is a 120-volt (V) 20 amp (A) straight blade receptacle, National Electrical Manufacturer's Association (NEMA) number 5-20R. This receptacle accepts NEMA plug numbers 5-15P and 5-20P. Each receptacle on the duplex is capable of drawing 20A.
<b>Reference 3 – 240V Receptacle</b>	The locking device is a 240V 20A NEMA L6-20R receptacle. This receptacle accepts a NEMA plug number L6-20P.
<b>Reference 4 – Ground Screw</b>	Ground the generator via the ground screw, to a copper pipe or rod that is driven into moist soil.
<b>Reference 5 – 7/8" diameter shaft</b>	The shaft is 1.50" long and has a 3/16" keyway.
<b>Reference 6 – Mounting feet</b>	Use these three locations to bolt the generator head in place.
<b>Reference 7 – Fan Vents</b>	Never block the vent slots or insert objects through the slots.

# Power Load Planning & Management

## **WARNING**

NEVER exceed the rated wattage capacity of your generator.  
 OVERLOADING may cause SERIOUS DAMAGE to the generator and attached electrical devices, and may result in fire.

Your generator **MUST BE SIZED PROPERLY** to provide both the running and starting (surge) wattage of the devices you will be powering. Before using your generator, determine the running and starting wattage requirements of all the electrical devices you will be powering simultaneously. The sum of the running and starting wattages of the devices being powered must not exceed the continuous output rating of your generator. (The continuous output rating of your generator is listed in the “Specifications” section of this manual.) Note that:

- Devices without electric motors such as light bulbs, radios, and televisions have the same running and starting wattage.
- Devices with electric motors such as refrigerators, compressors, and hand tools typically require a starting wattage that is 3 to 5 times greater than the running wattage.

The running and starting wattage requirements are often listed on a device’s nameplate. If wattage is not given on the device’s nameplate, the wattage may be calculated by multiplying the nameplate voltage by nameplate amperage,  $\text{Watts} = \text{Volts} \times \text{Amps}$ .

**Example conversion to watts:**

$$120 \text{ Volts} \times 5 \text{ Amps} = 600 \text{ Watts}$$

If only the running voltage is given on the nameplate for a device with an electric motor, the starting wattage can be approximated to be three to five times the running wattage.

Estimates for the running wattage requirements for common devices are listed in **Table 4** below. Guidance for starting wattages is provided in the table’s footnotes.

**Table 4**

Device	Running Watts	Device	Running Watts
Air conditioner (12,000 BTU)	1700 (a,b)	Jet pump	800 (a)
Battery charger (20 Amp)	500	Lawn mower	1200
Belt sander (3")	1000	Light bulb (100 Watt)	100
Chain saw	1200	Microwave oven	700
Circular saw (6½")	2000 (a,b)	Milk cooler	1100 (a)
Coffee maker	1800 (a,b)	Oil burner on furnace	300
Compressor (1 HP)	1400 (a,b)	Oil-fired space heater (140,000 Btu)	400
Compressor (¾ HP)	1800 (a)	Oil-fired space heater (85,000 Btu)	225
Compressor (½ HP)	1400 (a)	Oil-fired space heater (30,000 Btu)	150
Curling iron	700	Oven	4500
Dishwasher	1200	Paint sprayer, Airless (1/3 HP)	600 (a)
Edge trimmer	500	Paint sprayer, Airless (handheld)	150
Electric nail gun	1200	Radio	200
Electric range (1 element)	1500	Refrigerator	600 (b)
Electric skillet	1250	Slow cooker	200

## Power Load Planning & Management (cont'd)

Device	Running Watts	Device	Running Watts
Furnace fan (1/3 HP)	1200 (a)	Submersible pump (1-1/2 HP)	2800 (a)
Freezer	800 (b)	Submersible pump (1 HP)	2000 (a)
Hair dryer	1200	Submersible pump (1/2 HP)	1500 (a)
Hand drill (1")	1100	Sump pump	600 (a)
Hand drill (1/2")	875	Table saw	2000 (a)
Hand drill (3/8")	500	Television	500
Hand drill (1/4")	250	Toaster	1000
Hedge trimmer	450	Vacuum cleaner	250
Home computer	150	VCR	70
Impact wrench	500	Water Heater	3000
		Weed trimmer	500

(a) Hard-starting motors require 3-5 times the rated running watts

(b) For extremely hard to start loads such as air conditioners and air compressors, consult the equipment dealer to determine maximum wattage

**To calculate the running and starting wattage requirements for the devices you will be powering, follow these steps:**

1. Make a list of all electrical devices you will be powering at the same time with the generator.
2. List the greater of the running or starting wattage next to each device as obtained from the devices' nameplate or **Table 4**. If only the running wattage for a device with an electric motor is known, the starting wattage can be estimated to be at least 3 times the running wattage.
3. Add the wattages for all devices on your list. This total must be lower than the continuous output rating of your generator.

**Example:**

Device to be Powered	Greater of Starting/Running Wattage
Light Bulb	75 W
Refrigerator – 18 Cu. Ft.	1600 W
Microwave	700 W
Window AC	1800 W
Sump pump (1/3 hp)	2100 W
<b>Total</b>	<b>6275W</b>

In this example, the generator must have a continuous output of at least 6275 W in order to power all of the devices simultaneously.

### STAGGERING LOADS

You can increase the number of devices your generator can power by staggering the load on the generator. For example, you could alternately power your refrigerator and air conditioner for limited periods of time -- powering only one of the devices at a time and never powering both at the same time.

## Installation / Initial Set-Up

There are a number of important steps required to set up your generator for initial use. These steps are:

### **Steps for Installation / Initial Set-Up**

- 1. Unpacking & delivery inspection.**
- 2. Planning the power load to stay within the generator's rated capacity.**
- 3. Setting up for the type of power generation you need:**
  - a. portable power source, or**
  - b. connected to a building as a back-up power source.**
- 4. Selecting a site for using the generator.**
- 5. Mounting & connecting generator and engine.**
- 6. Grounding.**

Each of these steps is discussed in detail below:

### **1. Unpacking & Delivery Inspection**

1. You should inspect the generator immediately after you receive delivery.

*See the "Machine Component Identification" section of this manual for a diagram of the generator and its components.*

- If you have missing or damaged components, contact Product Support at 1-800-270-0810.

### **2. Planning the Power Load**

Plan your power load so that you do not exceed the generator's rated capacity.

See the "Power Load Planning & Management" section of this manual to review how to plan and manage power loads for the generator.

## Installation / Initial Set-Up

### 3. Set-up either as a BUILDING BACK-UP or PORTABLE Power Source

This generator is designed to provide up to 5000W of continuous electrical power. It can supply electricity in two ways:

1. **As a back up, standby power source for a building.** For this application, you must arrange for a licensed electrician to connect the generator to your building's electrical system via the installation of an UL-approved transfer switch. The transfer switch must be installed in accordance with building electrical code and guidelines supplied by your power company.
2. **As a portable power source.** You can plug appliances or tools directly into the generator's electrical outlets.

Specific requirements for each are given below.

Note: Regardless of whether you use your generator as a back-up power source connected to a building or as a portable power source, you must not overload the generator. Overloading may cause serious damage to the generator and attached electrical devices.

#### Using as a Back-up Power Source for a Building

**Contact a licensed electrician to install an UL-approved transfer switch** if you want to use your generator as a back-up power source for a building.

What does a transfer switch do? It:

- a) Safely connects the generator to your building's electrical system by isolating your generator from your utility company's power lines, AND
- b) Connects your generator to a critical subset of your building's circuits that are needed for emergency power needs.

If your generator will be connected to your building's electrical system, it **MUST ALWAYS** be isolated from the utility power grid with a *UL-approved transfer switch installed by a licensed electrician* in compliance with all applicable building and electrical codes, and in accordance with guidelines supplied by your power company.

#### **DANGER:**

A transfer switch must be installed in order to isolate your generator from the utility power grid. If your generator is **NOT** properly isolated from the utility system, serious hazards will arise:

- ◆ When your generator is running, it's output will back feed into the utility power line and transformer that are normally used to provide you with power. The transformer will step up the current to the normal line voltage. An unsuspecting utility line worker working on what he thinks is a deactivated line could be electrocuted.
- ◆ If your generator is connected (running or not) when utility power is restored, your generator will be destroyed. It could also explode or cause fire.

## Installation / Initial Set-Up

In addition to isolating your generator from the utility system, the transfer switch connects your generator to a limited set of circuits in your building that have been chosen as critical to operate during a power outage.

This generator can power up to 5,000 watts, which may not power your entire home or farm outbuilding -- you must work with the installing electrician to determine which devices/appliances you wish to power during an outage. The electrician can help you determine which circuits and devices can be powered simultaneously without overloading the generator.

(See the previous section of this manual entitled “Power Load Planning & Management” for more information on load application and selection.)

### Using as a Portable Power Source

**When using the generator as a portable power source, you can plug electric devices and appliances directly into the generator’s electrical outlets.**

There are two different kinds of electrical outlets on the generator:

1. One 240 Volt, 20 Amp locking receptacle (NEMA L6-20R locking receptacle compatible with L6-20P mating plug)
2. One 120 Volt, 20 Amp duplex straight-blade receptacles (NEMA 5-20R duplex receptacles compatible with NEMA 5-20P or 5-15P mating plugs).

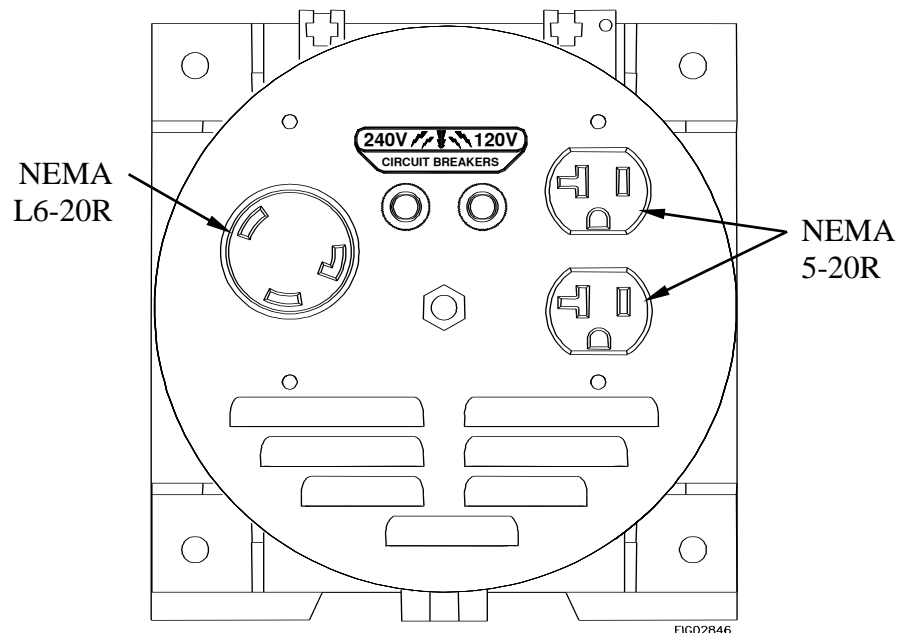

(See more technical detail about these receptacles and their associated circuit breakers in the “Machine Component Identification” section of this manual.)

## Installation / Initial Set-Up

- ◆ Make sure you plug each electrical device/appliance into the correct generator outlet based on the device's plug configuration and voltage/amperage rating. Never exceed the amperage rating of an outlet.
- ◆ Extension cords may be used to power devices that are located at a distance from the generator. However, use only UL-listed, outdoor-rated, grounded extension cords of the proper size. Additionally, if using the generator in damp or highly electrical conductive areas or on construction jobsites, always use ground fault circuit interrupter (GFCI)-equipped extension cords to prevent electrical shock. Use Table 5 below to choose an adequately sized extension cord according to the amperage of the device being used and the length of the cord.

**Table 5**

Current/Power		Maximum Extension Cord Length			
Amps at 240V	Load (watts)	#10 Ga. Cord	#12 Ga. Cord	#14 Ga. Cord	#16 Ga. Cord
10	2400	250'	150'	100'	75'
20	4800	125'	75'	50'	25'
30	7200	60'	35'	25'	10'
40	9600	30'	15'	10'	*
50	12000	15'	*	*	*

** WARNING:**

Use of under sized extension cords can cause electric shock, fire, or damage to connected devices. Failure to use GFCI extension cords in damp or wet conditions can result in severe electric shock or electrocution.

- ◆ All extension and appliance cords must be in good condition and not worn, bare, frayed, or otherwise damaged.

** WARNING:**

Use of damaged electric cords can cause electric shock or fire.

Note: If an extension cord becomes hot to the touch, it is overloaded or damaged and must be replaced.

*Northern Tool is NOT responsible for damage or injury resulting from customer use of inadequate extension cords.*

# Installation / Initial Set-Up

## 4. Select a Suitable Site

Before using the generator, you must select a suitable **OUTDOOR** location for installation and operation of your generator. The location should meet all the criteria listed below.

**⚠ WARNING:**

You must choose a suitable site for operating your generator to avoid equipment damage and/or injury and possible death from carbon monoxide poisoning, electric shock, or fire. Choose a site that meets all of the criteria specified below.

### Site/Location Criteria:

<b>Dry, level surface</b>	<p><b>The generator should be positioned on a dry, firm, level surface.</b> Ensure that the generator sits level and will not slide or shift during operation.</p>
<b>Outdoors only – dangerous carbon monoxide exhaust</b>	<p><b>⚠ DANGER: Carbon monoxide poisoning hazard</b> The exhaust from the engine contains carbon monoxide (CO), a poisonous gas that can kill. You cannot smell it, see it, or taste it. Follow the directions below for choosing a location to operate your generator in order to avoid carbon monoxide poisoning.</p> <p><b>The location you choose to operate the generator must be OUTDOORS and away from all air intakes:</b></p> <ul style="list-style-type: none"> <li>• Never run the generator/engine assembly inside any closed or semi-enclosed spaces (even if outdoors), including homes, garages, basements, barns, sheds, or boxes. <i>These spaces can trap poisonous gases, even if you run a fan or open windows.</i></li> <li>• Place the generator so that the exhaust fumes from the engine will not be directed towards people or building air intakes.</li> <li>• Ensure that working, battery-operated or battery back-up carbon monoxide alarms are used in any dwelling/structure that is in close proximity to the running generator.</li> <li>• Note that this generator is NOT designed or approved for use in vehicles or marine applications. Never run the generator inside RVs or other vehicles, on boats, or on pick-up truck beds.</li> </ul> <p><b>⚠ WARNING:</b> Never attempt to attach ductwork to the engine exhaust to allow for installation inside an enclosure. This could cause hot air deflection, heat build-up, and increased exhaust back-pressure, resulting in possible exhaust leakage or damage to the generator or engine.</p>
<b>Adequate cooling ventilation</b>	<p><b>The generator needs adequate, unobstructed flow of air to allow for proper cooling of generator head.</b></p> <ul style="list-style-type: none"> <li>• Situate so there is adequate clearance around generator to allow for cooling airflow so that heat does not build up. Never block vent slots. The closest object should be at 7 feet away from vents.</li> </ul>



## Installation / Initial Set-Up

	<ul style="list-style-type: none"> <li>• Do not run the generator in close proximity to other heat-generating equipment, such as another generator. The combined heat that is generated may raise air temperature in the immediate area and there will not be adequate cooling ventilation.</li> <li>• Do not allow debris to accumulate and block airflow.</li> <li>• Do not operate with a tarp, blanket, or cover surrounding the generator.</li> </ul>
<b>Hot engine exhaust clearance</b>	<p><b>The exhaust gas from your engine is extremely hot and can cause combustible materials to catch on fire.</b></p> <ul style="list-style-type: none"> <li>• Position engine exhaust at a safe distance from all nearby combustible materials and buildings/structures. Refer to your engine manual to determine the safe clearance distance required.</li> <li>• Equip the engine with a spark arrestor if the generator will be used near any ignitable forest, brush, or grassy land. Make sure you comply with applicable local, state, and federal codes.</li> <li>• Keep a fire extinguisher rated “ABC” nearby. Keep it properly charged and be familiar with its use.</li> </ul>
<b>No wet conditions</b>	<p><b>Choose a location where the generator will NOT be exposed to rain, snow, or direct sunlight.</b> Exposure to water can cause electric shock.</p> <p>You <i>may</i> operate the generator under an outdoor, canopy-like structure of heat-resistant material that is open on all sides. Make sure that all parts of canopy are:</p> <ul style="list-style-type: none"> <li>• at least 7' from generator</li> <li>• at an adequate safe clearance from hot engine exhaust.</li> </ul> <p>Allow for adequate clearance above generator so that heat from generator does not build up.</p>
<b>Away from dust/dirt</b>	<p><b>Do not use the generator in extremely dusty or dirty conditions.</b> Excessive dust and dirt can cause premature failure of the machine.</p>
<b>Hearing protection</b>	<p><b>Generators can produce noise levels of up to 95 dB in close proximity, which can be dangerous to human hearing with prolonged exposure.</b> (This is in addition to the noise produced by the engine.)</p> <p>Hearing protection may be required for persons working within 15-20 feet of the running generator for an extended period of time.</p> <p><b>⚠️ WARNING:</b>  Never attempt to attach ductwork to the engine exhaust to lower noise levels. This could cause hot air deflection, heat build-up, and increased exhaust backpressure, resulting in possible exhaust leakage or damage to the generator or engine.</p>

## Installation / Initial Set-Up

### 5. Mount & Connect Generator and Engine

**You will need to supply a minimum 11 HP engine to power the generator.**

**There are two methods to connect the generator to the engine:**

1. The recommended method is to use **sheaves (pulleys) and a V-belt(s)**.
2. An alternative method is to **direct couple** the generator to the engine. However this method requires great care to align the shafts of the generator and engine to within the specified tolerances of the chosen coupler.

In either case, **the engine-generator assembly must be properly mounted & guarded**. Note that the customer is responsible for obtaining and installing an appropriate guard.

#### Mounting:

The engine and generator must be **mounted to a common base** such as a heavy-duty metal plate. Secure mounting will ensure that the generator will not lift or flip during use. In addition, all engines vibrate and the generator must move with the engine to prevent excessive belt slippage or misalignment of couplings.

#### Guarding:

-The power transmission assembly must be equipped with a **guard that prevents contact with all rotating shafts, pulleys, belts, and couplings**. Clothing or hair can become rapidly entangled in unguarded rotating parts, resulting in *serious injury or death*.

-This guard is not supplied with the generator because the manufacturer does not know the dimensions of the engine to be used, nor in what configuration the customer will choose to mount the generator & engine.

Follow the detailed instructions below for mounting, connecting, and guarding the engine-generator assembly.

#### **Mount to a common base**

**Mount the generator and engine to a common base** such as a heavy-duty metal plate of at least ¼" thickness.

#### **WARNING:**

Failure to properly mount the generator may cause the unit to lift or flip during use, which could result in severe injury to the operator or bystanders, or cause damage to surrounding objects.

1. Choose a mounting base that is of adequate size and strength to withstand operating torque and vibration without either flipping or experiencing stress failure. Plate should be at least ¼" thick.

## Installation / Initial Set-Up

2. See below for a possible mounting configuration. Note: Guards are removed to show details.

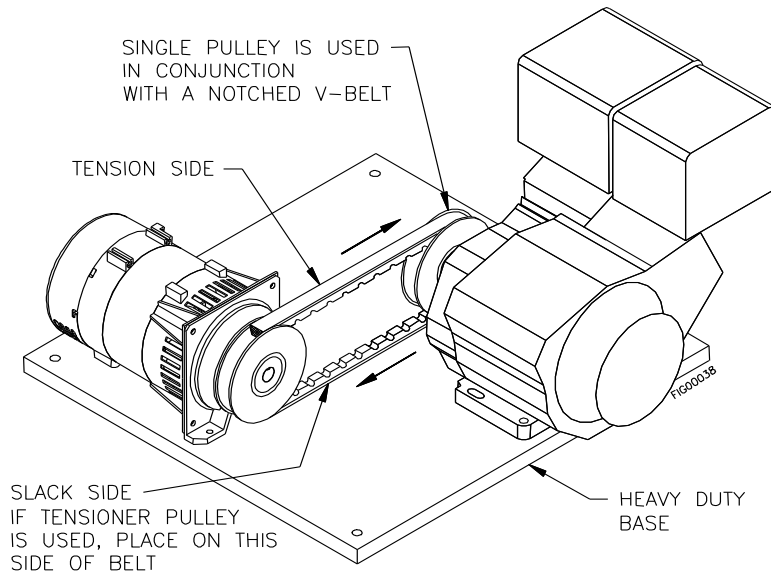

3. Bolt the generator to the mounting base using three, 1/2" grade 8 bolts. See below.

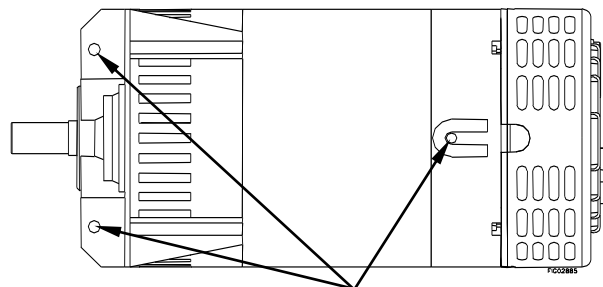

Mounting Holes

### Connect generator to engine

**Connect the generator to the engine using sheaves (pulleys) and V-Belt(s):**

1. **Select the correct sheaves and belts for this application.**

The generator shaft is 7/8" diameter x 1.5" long with a 3/16" keyway. Use **Table 6** below to select the correct sheaves and belts for this application.

**Table 6:**

Option	Sheaves		Belt(s)	
	Diameter	Single vs. Double	Type	Quantity
#1	5.8"	Single	Notched V-Belt	1
#2	5.0"	Double	V-Belt	2

Note that a notched V-belt requires only one sheave, while the standard V-belt requires 2 side-by-side sheaves and 2 V-belts.

## Installation / Initial Set-Up

The shaft speed of the generator must run between 3540-3780 RPM. At no load, the correct speed is 3780 RPM.

- If the engine is a 3600 RPM engine, then a sheave diameter ratio of 1:1 should be used. This means that the diameter of the sheave on the engine is the same as the diameter of the sheave on the generator.
- If the engine is rated at a speed less than 3600 RPM, you will need to use a larger sheave on the engine, using the following formula:

$$\frac{\text{Engine Speed (RPM)}}{3600 \text{ RPM}} = \frac{\text{Generator Sheave Diameter}}{\text{Engine Sheave Diameter}}$$

If smaller than recommended sheaves are used, the life of the belt(s) will be shortened and the possibility of belt slippage increases.

### Note about direct coupling:

We recommend you use belts & sheaves to transmit power from the engine to the generator. If you instead choose to direct couple, you must align the generator shaft and engine shaft exactly to within the specified tolerances of the chosen coupler. You will need to adjust the relative position of the generator and engine until both their shafts are directly aligned in all planes.

### 2. Adjust belt(s) to get proper tension.

Proper belt tension is required to transmit full power from the engine to the generator at the rated speed. Belts that are too loose will slip. Belts that are too tight can bind and cause engine or generator damage.

#### **⚠ WARNING:**

Belt slippage can cause static electricity build-up, which may result in sparking. Fire ignition can result.

**Step 1.** Measure **L** – the center-to-center distance between the two sheaves.

**Step 2.** Measure **d** – the deflection of the belt

**Step 3.** Tighten or loosen belt until:

$$d = 0.016 \times L$$

If a belt tensioner is used, it should be installed on the slack run of the belt.

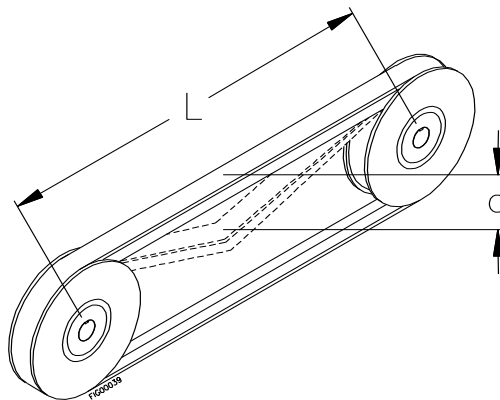

## Installation / Initial Set-Up

### Acquire & install guard

#### Install a guard over the entire power transmission assembly.

The customer is responsible for acquiring or fabricating an appropriate guard that meets all the requirements described in this section.

Note: A guard has not been supplied with the generator because the manufacturer does not know the size and dimensions of the engine to be used, nor in what configuration the customer will choose to mount the generator & engine.

#### **⚠ DANGER:**

All parts of the power transmission assembly must be equipped with a guard that prevents access to rotating parts. Clothing or hair can become rapidly entangled in unguarded rotating parts, resulting in serious injury or death.

**Guard requirements.** The guard must:

- 1) Prevent contact with all rotating shafts, pulleys, belts, and couplings.
- 2) Allow for adequate cooling ventilation and hot exhaust clearance, as described in the previous section “4. Select a Suitable Site”.
- 3) Be constructed of non-combustible, heat-resistant, durable and impact-resistant material.

Expanded metal, perforated or solid sheet metal, wire mesh on a frame of angle iron, or iron pipe securely fastened to the frame can be used.

Openings in, around, and between guards can allow fingers/hands to protrude into dangerous areas where hazards exist. The allowable size of openings depends on the distance of the opening from specific hazards. Follow the OSHA guidelines below (extracted from 20 CFR 1910.217 Table O-10) for maximum opening size:

Distance of Guard Opening from Moving Parts	Maximum Width of Guard Opening
½” to 1½”	¼”
1½” to 2½”	⅜”
2½” to 3½”	½”
3½” to 5½”	⅝”
5½” to 6½”	¾”
6½” to 7½”	⅞”

**Figure 7** below illustrates a properly guarded power transmission assembly.

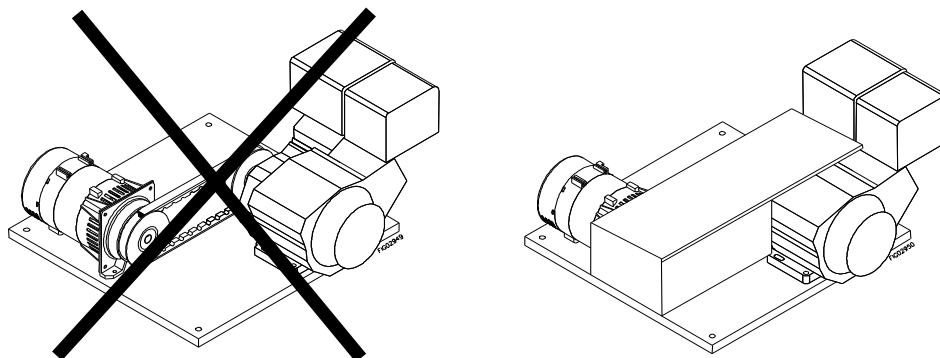

## Installation / Initial Set-Up

### 6. Ground the generator

**Always ensure the generator is properly grounded to prevent electrical shock.**

You must always ground the generator by the following method when using the generator as a portable electrical source:

- 1) Drive a  $\frac{3}{4}$ " or 1" copper pipe or rod into the ground close to the generator. The pipe/rod must penetrate moist earth – the depth required will be dictated by local soil conditions. Consult with an electrician.
- 2) Connect an approved ground clamp to the pipe.
- 3) Run a 10-gauge wire from the clamp to the generator grounding screw.
- 4) Do not connect the generator grounding post to a water pipe or a ground used by a radio system.

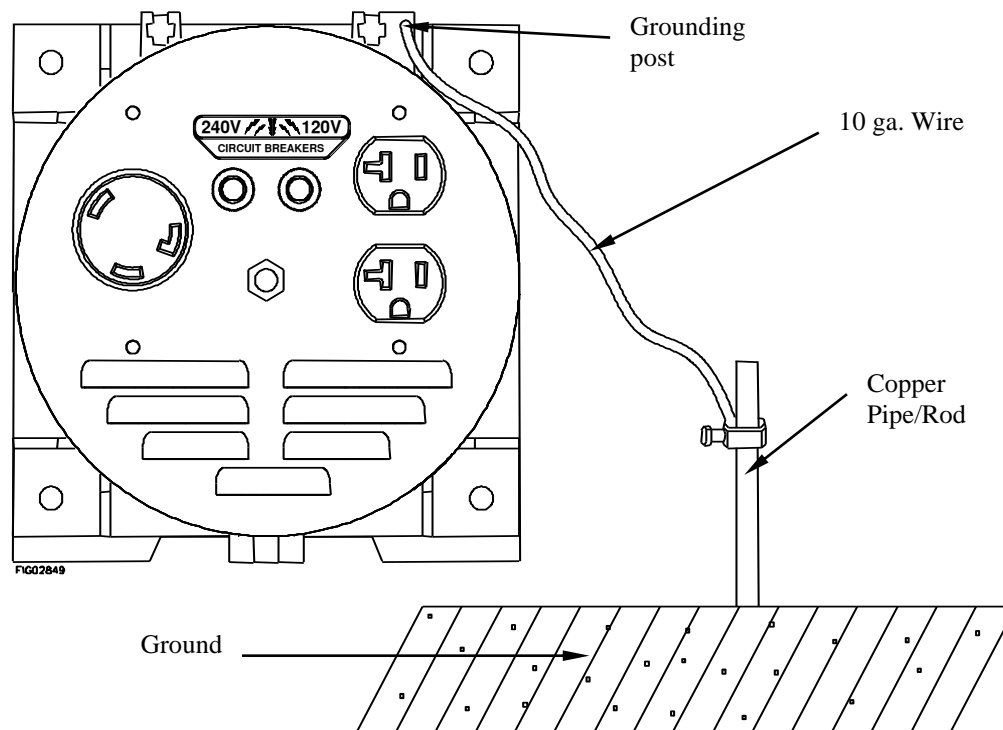

- 5) The generator must be grounded every time it is moved.

If a licensed electrician installs the generator with a connection to your building's electrical circuit for use as a back-up power system, grounding may alternatively be completed through the building's grounding system. Ask your electrician. If the generator is not grounded through your building's electrical system, follow the procedure above.

**⚠ WARNING:**

Operating the generator when it is not properly grounded can result in electrical shock.

# Operation

Once you have set up your generator for use, it is time to start your generator. The following are the procedures necessary for safe, successful operation of your generator.

## Operation Procedures

1. **General Safety Rules for Operation**
2. **Preparing for Operation (Pre-start checklist)**
3. **Starting the Generator**
4. **Connecting Loads**
5. **Stopping**
6. **Storage & Exercise**

Each of these procedures is discussed in detail below:

### 1. General safety rules for operation

**Before starting the generator, review the following general safety rules for operation:**



#### **WARNING:**

Failure to follow safety rules may result in serious injury or death to the operator or bystanders.

- **Know proper use/how to stop.** Be thoroughly familiar with proper use of the equipment and all generator controls, output receptacles, and connections. Know how to stop the generator quickly if needed. Refer to the engine manual for engine safety rules and operating instructions.
- **Instruct operators.** The generator owner must instruct all operators in safe generator set-up and operation. Only trained adults should set up and operate the generator – Do not let children operate.
- **Intended use.** Carefully read about and understand the intended use of this generator. Do not use for other purposes, as unforeseen hazards or equipment damage may result.
- **Under the influence.** Never operate, or let anyone else operate, the generator while under the influence of alcohol, drugs, or medication.
- **Safety guards / controls.** Do not operate the generator unless all safety covers, guards, and barriers are in place and in good working order, and all controls are properly adjusted for safe operation
- **Damaged.** Do not operate the generator with damaged, missing, or broken parts.
- **Modifications.** Do not modify the generator in any way. Modifications can create serious safety hazards and will also void the warranty.
- **Malfunction during operation.** Immediately turn off the generator if any of the following conditions arise during operation:
  - Excessive change in engine speed, slow or fast
  - Overheating in load connecting devices
  - Sparking or arcs from generator
  - Loss of electrical output
  - Receptacle damage
  - Excessive vibration
  - Flame or smoke
  - Abnormal noise

## Operation (cont'd)

- **Adjusting / repairing.** Before working on the generator or engine, always turn off engine and remove spark plug(s) or spark plug wire(s) to prevent accidental starting. Always discharge the capacitor before working on the generator head to prevent electrical shock. (See Maintenance & Repair section of this manual for instructions on how to do this.)
- **Carbon monoxide poisoning.** The running engine gives off carbon monoxide, a poisonous gas that can kill you. You CANNOT smell it, see it, or taste it. Follow all instructions for site selection and positioning the generator, and avoid inhaling the exhaust. If you start to feel sick, dizzy, or weak, shut off the engine and get to fresh air RIGHT AWAY. See a doctor. You may have carbon monoxide poisoning.
- **Electrical cords.** Use only UL-listed, outdoor-rated, three prong extension cords of the proper size. All extension and appliance cords must be in good condition and not worn, bare, frayed, or otherwise damaged. Use of inadequate or damaged electric cords can cause electric shock or fire.
- **GFCI extension cords.** Always use ground fault circuit interrupter (GFCI)-equipped extension cords in damp or highly electrical conductive areas and on construction jobsites to prevent electrical shock.
- **Avoid contact.** Avoid contact with bare wires, terminals, connections, etc. while the unit is running.
- **Wet conditions.** Do not operate the generator or handle any electrical equipment while standing in water, while barefoot, while hands are wet or while in the rain or snow. Electric shock may result.
- **Electric shock accident.** If an electric shock accident occurs, immediately shut down the source of electrical power. If this is not possible, attempt to free the victim from the live conductor. Avoid direct contact with victim. Use a nonconducting implement, such as a dry rope or board, to free the victim from the live conductor. Apply first aid and get immediate medical help.
- **Smoking/sparks.** Never smoke near the running generator, and never operate near sources of sparks or flames.
- **Hot parts.** Parts of the engine and generator are extremely hot during and after operation and can burn you. Never touch hot muffler, hot exhaust manifold or any other part of the engine or generator unless you have first determined if it is hot. Wait a sufficient time for parts to cool before touching any part of the generator or engine.
- **Moving parts.** Keep hands, feet, and apparel away from drive belts, sheaves, couplings, fans, and other moving parts. Never attempt to remove any guard or shield while the unit is operating.



## Operation (cont'd)

### 2. Preparing for Operation (Pre-start checklist)

<b>Mount generator &amp; engine</b>	<p><b>Check that the generator and engine are mounted and connected</b> in accordance with the instructions given earlier in this manual in the “Installation / Initial Set-up” section, “Step 5: Mount &amp; Connect Generator and Engine”.</p> <p><b>⚠ WARNING:</b> Always ensure generator and engine are properly mounted to prevent flipping and belt slippage during use, which could cause equipment damage and injury to nearby persons, as well as development of sparks from static electricity.</p>
<b>Position generator</b>	<p><b>Check that the generator is positioned</b> in accordance with the instructions given earlier in this manual in the “Installation / Initial Set-up” section, “Step 4: Select a Suitable Site”.</p> <p>Operate outside only, on dry, level ground with adequate clearance and ventilation.</p> <p><b>⚠ DANGER: Carbon monoxide poisoning hazard</b> The engine gives off carbon monoxide exhaust, a poisonous gas that can kill. You CANNOT smell it, see it, or taste it. ONLY run generator OUTDOORS and away from air intakes. NEVER run generator inside any enclosed or semi-enclosed spaces, including homes, garages, basements, barns, sheds, boxes, pick-up truck beds, RVs, or boats. These spaces can trap poisonous gases, EVEN if you run a fan or open windows.</p>
<b>Ground generator</b>	<p><b>Make sure the generator is grounded</b> in accordance with instructions given earlier in this manual in the “Installation / Initial Set-up” section, “Step 6: Grounding the Generator”.</p> <p><b>⚠ WARNING: Electric shock hazard</b> Always ensure generator is properly grounded to prevent electrical shock.</p> <p><b>IMPORTANT:</b> The generator must be grounded every time it is moved.</p>
<b>Perform regular inspection/maintenance</b>	<p><b>Make sure that any regular maintenance has been performed:</b></p> <ul style="list-style-type: none"> <li>• On the <b>generator</b> as prescribed in this manual in the “Maintenance &amp; Repair” section;</li> <li>• On the <b>power transmission system</b> (belts, pulleys, couplings) as prescribed in this manual in the “Maintenance &amp; Repair” section; and</li> <li>• On the <b>engine</b> as prescribed in your engine manual, including adding/changing the oil.</li> </ul> <p><b>IMPORTANT:</b> Under long, continuous-run operating conditions, be prepared to check the engine oil level every time you refuel the engine. Remember to change the oil at the operating interval recommended in the engine owner’s manual.</p> <p><b>DO NOT</b> start the generator until any needed repairs have been completed.</p>

## Operation (cont'd)

### Check/fill fuel tank

**Check the engine fuel level. If needed, fill tank with fresh fuel from a portable container** after first reading the following instructions and warnings:

- 1) Allow engine to cool for at least two minutes before removing gas cap.  
Note: A running or still-hot engine is hot enough to ignite fuel.
- 2) When adding fuel:
  - Use only a UL-approved portable fuel container to transfer fuel. Follow the safety warning and instructions below for avoiding static electric sparking.
  - Do NOT overfill the fuel tank. Allow some space for fuel expansion.
  - Fill fuel tank **OUTDOORS** – never indoors.
  - Stay away from all sources of heat, sparks, and flames. Do not smoke.
- 3) Clean up fuel spills /splashes immediately.
  - If possible, move the generator away from spilled fuel on the ground.
  - Wipe up spilled fuel, and wait 5 minutes for excess fuel to evaporate before starting engine.
  - Fuel soaked rags are flammable and should be disposed of properly.
  - If fuel is spilled on your skin or clothes, change clothes and wash skin immediately.
- 4) Store extra fuel in a cool, dry place in an UL-approved, tightly sealed container.

***IMPORTANT:***

For continuous operation, be prepared to check and refuel the engine on a regular basis.

**SPECIAL HAZARDS DURING FUELING:**

** WARNING: Fuel fire/explosion hazard**

Gasoline is highly flammable and explosive, and standard diesel fuel is combustible. Heat, sparks, and flames can ignite fuel vapors, which can become widespread during fueling. A flash fire and/or explosion could result and cause serious injury or death. Use extreme care when handling fuel. Carefully follow all the instructions in this section to avoid the following conditions which could result in fuel vapor ignition:

- fuel vapor collection inside enclosures
- static electric sparks
- sparks from electric wiring, batteries, or running engines
- sources of heat (such as a hot engine or exhaust)
- open flames, including pilot lights

** WARNING: Static electric spark hazard**

A static electric spark can ignite fuel vapor, resulting in a flash fire that could cause serious injury or death.

To avoid static electric sparking while filling the fuel tank, **the following steps must be followed to minimize and safely dissipate static electric charge build-up before and during the fueling process:**

## Operation (cont'd)

	<ul style="list-style-type: none"> <li>• Always dissipate static charge from your body before beginning the fueling process by touching a grounded metal object at a safe distance from fuel sources.</li> <li>• Never fill the generator's fuel tank directly from the pump – the generator's tank is not grounded and high velocity flow from the pump can cause static electricity build-up. Use an approved portable container to transfer gas to the generator's tank.</li> <li>• Never fill the portable gas container while it is sitting inside a vehicle, trailer, trunk, or pick-up truck bed. ALWAYS place container on the ground to be filled.</li> <li>• Keep nozzle in contact with portable container while filling. Manually control the flow of fuel; do NOT use nozzle's lock-open device.</li> <li>• A portable container made of metal or conductive plastic is preferred because it dissipates charge to ground more readily.</li> </ul>
<p><b>Personal Protection</b></p>	<ol style="list-style-type: none"> <li>1. Hearing can be damaged from prolonged, close-range exposure to the type of noise produced by this generator. <b>The use of ear plugs or other hearing protection device is recommended</b> for persons working within 15-20 feet of the running generator for an extended period of time.</li> <li>2. Loose or dangling apparel and long hair can become quickly entangled in moving/rotating parts. Metal jewelry can conduct electricity. <b>Never wear jewelry or loose-fitting clothing</b> such as neckties, scarves, or long-sleeved or untucked shirts <b>when starting or adjusting the generator. Tie back and secure hair</b> close to the head.</li> </ol>

## Operation (cont'd)

### 3. Starting the Generator

**After you have completed the pre-start checklist procedures, you are ready to start the generator.**

#### Start engine

**Start the engine with the guard in place.**

- Before starting, confirm there are no loads connected to the generator's outlets.
- Follow the instructions provided in your engine manual for starting the engine.

#### Check output voltage without load

**Check output voltage before connecting loads to the generator.**

** WARNING:**

The generator must be run at the correct speed in order to produce the proper electrical voltage and frequency. Failure to do so could result in damage to equipment powered by the generator and possible injury to the individual.

1. Allow running generator to warm up for five minutes. Do not connect any loads.
2. Use portable voltage meter to check output voltage at the generator's outlets/receptacles.
3. Measured voltage should be within the following ranges:
  - a. 108-132 volts at 120V receptacle(s).
  - b. 216-264 volts at 240V receptacle(s).

If the output voltage is NOT within the specified range:

- 1) Adjust the engine speed if possible.
- 2) If that doesn't work, re-verify that:
  - a) Your engine's rated horsepower meets the minimum requirement,
  - b) Your sheave ratio is correct, and
  - c) The belts (or couplings) are not loose (squeaking, visibly slipping).
- 3) If you are still not able to achieve acceptable output voltage, there is a problem with the engine or the generator. Refer to your engine's owner's manual for troubleshooting. If it appears that the generator itself is the problem, call NorthStar Product Support @ 1-800-270-0810 for assistance.

## Operation (cont'd)

### 4. Connecting Loads

You will want to be careful when connecting loads so as not to overload the generator, especially if you are powering devices with motors that require a higher starting power load.

Instructions are provided below for connecting loads when you are using the generator:

- As a portable power source
- Connected to a building as a back-up power source



#### **WARNING:**

Do not overload generator. Make sure that combined starting and running loads do not exceed rated capacity of generator. Overloading the generator can cause damage to the generator and attached electrical devices, and may result in fire.

#### **Using as a Portable Power Source**

#### **Connect electrical loads one at a time according to the following instructions:**

1. Allow engine to reach operating speed by allowing it to warm up for approximately 5 minutes before connecting electrical devices.
2. After engine is warmed up, begin connecting the loads one at a time. Start with those that require the highest wattage first. The recommended sequence is as follows:
  - a. Connect items with motors such as refrigerators, freezers, air conditioners, or small hand tools, one at a time. Let each motor stabilize before connecting the next device.
  - b. Connect any lights you are planning on powering.
  - c. Connect voltage sensitive equipment such as electronics via surge protectors. Plug devices such as TV's, computers, and microwaves into a UL listed voltage surge protector, then plug the surge protector into the generator.
3. After connecting all loads, check output voltage again (for generator's first use, and periodically after that). Output voltage should remain within the following ranges:
  - a. 108-132 volts at 120V receptacle(s).
  - b. 216-264 volts at 240V receptacle(s).

If output voltage is not within the acceptable range, adjust the engine speed (if possible). If acceptable output voltage cannot be achieved no matter what the engine speed, the generator is either overloaded or there is a problem with either the engine or the generator. Shut off the engine and refer to the Troubleshooting guide at the end of this manual for assistance with possible problems.



#### **WARNING:**

The generator must be run at the correct speed in order to produce the proper electrical voltage and frequency. Failure to do so could result in damage to equipment powered by the generator and possible injury to the individual.

## Operation (cont'd)

	<p><u>Note:</u> <i>Expect slight variations in voltage/speed with changing electrical loads. All engines have a tendency to slow down when a load is applied. When electrical loads are connected to the generator, the engine is more heavily loaded and as a result the speed drops slightly. This slight decrease in speed, together with the voltage drop within the generator itself, results in a slightly lower voltage when the generator is loaded to its full capacity than when it is running with no load. Additionally, there may be small brief surges and drops in voltage as motors connected to the generator cycle on or off. The slight variation in voltage has no appreciable effect in the operation of motors, lights, and most appliances, as long as output voltage remains in the acceptable range of 108-132 volts at the 120V receptacle(s) and 216-264 volts at the 240V receptacle(s).</i></p>
<p><b>Using as a Back-up Power Source for a Building</b></p>	<p>Written instructions for how to safely bring the generator online with the building's electrical system should be provided by the electrician who installs the transfer switch, and who should also provide personal instruction to the owner/operator.</p> <p>Failure to follow the proper procedure as provided by the electrician could expose persons to the hazards noted above.</p> <p><u>Note:</u> After you have brought the generator online with the transfer switch, you may need to adjust engine speed to maintain correct output voltage under load. (See more detail about maintaining proper voltage in the instructions given above for using the generator as a portable power source.)</p>

## Operation (cont'd)

### 5. Stopping

**Stop the generator using the following steps:**

1. Disconnect all loads to generator.  
(Never turn off or reduce engine speed with electrical loads connected. Damage to generator and loads will occur.)
2. Shut OFF the engine
3. Shut OFF fuel supply to the engine if possible.
4. Remove spark plug to prevent accidental starting of engine.

### 6. Storage & Exercise

**When you are finished using the generator, you must:**

- Make sure all loads to the generator are disconnected and fuel supply is shut off (if possible)
- Store the generator properly
- Plan on exercising the engine regularly unless the generator is prepared for long-term storage.

Detailed instructions are provided below.

**Disconnect loads & shut off fuel supply**

**When you are finished using the generator, disconnect all loads and turn off fuel supply:**

1. Make sure all devices that were connected to the generator's outlets have been disconnected.
2. Make sure fuel supply to the engine has been shut off, if possible.

**Cool engine before storing**

**Let engine cool for at least five minutes before storing.** A hot engine can be a fire hazard.

**Choose a storage location**

**Store the generator in a location that is:**

- Clean and dry
- Away from sources of heat, open flames, sparks, or pilot lights, even if the generator's fuel tank is empty. Residual fuel in the engine's tank could ignite.
- Away from extreme high or low temperatures.

**Prevent accidental starting**

**Remove engine spark plug(s)** in order to ensure the generator cannot be started accidentally in a storage location or by untrained persons.

## Operation (cont'd)

<p><b>Exercise generator every 4 weeks</b></p>	<p><b>The generator should be exercised regularly.</b>          At least every four weeks, start the engine and let it run for 10 to 15 minutes with a small load plugged in, such as a lamp or fan.</p> <p>Monthly exercising of the generator will:</p> <ul style="list-style-type: none"> <li>○ Dry out any moisture that has accumulated in the windings. If left, this moisture can cause corrosion in the winding.</li> <li>○ Ensure that the unit is operating properly should it be needed in an emergency.</li> </ul>
<p><b>Perform regular maintenance</b></p>	<p><b>Perform periodic maintenance</b> as directed in this manual to keep the generator in safe working condition.</p>
<p><b>Prepare engine for long term storage if needed</b></p>	<p><b>If you will not be able to exercise the generator regularly, you must prepare the engine for long term storage</b> to prevent gum deposits from forming and causing malfunction of the engine.</p> <p>Prepare engine for long term storage by following instructions in your engine's manual or using the following procedure:</p> <ul style="list-style-type: none"> <li>○ <b>Removing all fuel</b> from the tank and carburetor</li> </ul> <p style="text-align: center;"><u>OR</u></p> <ul style="list-style-type: none"> <li>○ <b>Adding fuel stabilizer</b> to the fuel (following manufacturer's instructions)</li> </ul> <p style="text-align: center;"><u>Fuel stabilizer steps:</u></p> <ol style="list-style-type: none"> <li>1. Ensure fuel tank is full.</li> <li>2. Add fuel stabilizer to fuel tank.</li> <li>3. Run engine at least 10 minutes after adding stabilizer to allow it to enter the fuel system.</li> <li>4. Shut off engine</li> <li>5. Disconnect spark plug wire and remove spark plug</li> <li>6. Add one teaspoon oil through spark plug hole</li> <li>7. Place rag over spark plug hole and turn starter (or pull the recoil) a few times to lubricate the combustion chamber.</li> <li>8. Replace spark plug, but do not reconnect the spark plug wire.</li> </ol>



## Maintenance & Repair

Inspect and maintain your generator as specified below in order to keep it in safe and optimal working order. Follow all safety rules and recommended maintenance steps.

### **WARNING**

ALWAYS shut off the engine, disconnect the engine's spark plug(s), and discharge the capacitor before cleaning, adjusting, or servicing the generator. Make sure all guards and shields are replaced before using.

Note: The generator head is brushless and maintenance free. The bearing is a heavy-duty sealed ball bearing which requires no maintenance or lubrication.

### Maintenance & Repair

<b>Follow safety rules</b>	<p><b>Read and follow these safety rules whenever you will be servicing the generator:</b></p> <ul style="list-style-type: none"> <li>• <b>Turn off generator.</b> Always turn off generator and remove spark plug(s) or spark plug wire(s) before working on the engine or generator to prevent accidental starting.</li> <li>• <b>Discharge capacitor.</b> When the generator is shut down, the capacitor may maintain a charge. Always discharge the capacitor before working on the generator head to prevent electrical shock. Discharge using a screwdriver with an insulated handle. While wearing safety glasses, touch opposite terminals of the capacitor together with the tip of the screwdriver. If there is stored charge in the capacitor, a spark will be generated thereby discharging the capacitor.</li> <li>• <b>Replace guards.</b> Make sure all guards and shields are replaced after servicing the generator.</li> <li>• <b>Repair.</b> Major service, including the installation or replacement of parts, should be performed only by a qualified electrical service technician. Obtain factory approved parts from Northern Tool Product Support at 1-800-270-0810.</li> <li>• <b>Replacement parts.</b> If a part needs replacement, only use factory approved repair parts. Replacement parts that do not meet specifications may result in a safety hazard or poor operation of the generator and will void the warranty.</li> </ul>
<b>Check receptacles</b>	<p><b>Check receptacles before each use to make sure they are not cracked or broken.</b></p> <p>If a receptacle is cracked or otherwise damaged, do not use until replaced with an authorized factory part. Using cracked or damaged receptacles can be both dangerous to the operator and destructive to the equipment.</p>
<b>Keep generator clean</b>	<p><b>Keep generator clean.</b></p> <p>If dust or debris accumulates on the generator, clean the generator with a damp cloth or soft bristle brush. Do not allow air intakes to become blocked.</p> <p><u>Note</u>: Do not spray generator with a garden hose or pressure washer. Water may enter the generator and cause damage to the rotor, stator, or internal windings.</p>

## Maintenance & Repair (cont'd)

<b>Check mounting, belts and couplings</b>	<p><b>Check generator mounting, belts, and couplings on a periodic basis:</b></p> <ol style="list-style-type: none"> <li>1. Make sure that the mounting bolts are tight and secure.</li> <li>2. Check belt (if applicable) and pulleys for looseness or signs of wear. Adjust or replace as necessary.</li> <li>3. Check coupling (if applicable) for signs of wear or misalignment. Replace/realign as needed.</li> </ol>
<b>Perform engine maintenance</b>	<p><b>Perform engine maintenance as specified in the engine owner's manual.</b></p> <p>Engine maintenance items may include:</p> <ol style="list-style-type: none"> <li>1. Changing oil and oil filter</li> <li>2. Air filter check/replacement</li> <li>3. Spark plug cleaning and replacement</li> <li>4. Spark arrestor inspection and cleaning</li> <li>5. Fuel filter check/replacement</li> <li>6. Fuel tank cleaning</li> <li>7. Fuel line inspection/replacement</li> <li>8. Battery charging/maintenance.</li> </ol>

**IMPORTANT:**

If a part needs replacement, only use parts that meet the manufacturer's specifications. Replacement parts that do not meet specifications may result in a safety hazard or poor operation of the generator.

**Contact NorthStar Product Support at 1-800-270-0810 for any questions, problems, or parts orders.**

# Troubleshooting

<b><i>TROUBLESHOOTING</i></b>		
<b><u>Problem</u></b>	<b><u>Possible Causes</u></b>	<b><u>Possible Remedies</u></b>
Voltage too low.	<ul style="list-style-type: none"> <li>a) Engine speed too slow.</li> <li>b) Generator is overloaded.</li> </ul>	<ul style="list-style-type: none"> <li>a) Bring generator to a qualified technician for adjustment.</li> <li>b) Reduce the load. (See Power Load Planning &amp; Mgt. Section of this manual.)</li> </ul>
Circuit breaker trips.	<ul style="list-style-type: none"> <li>a) Defective load connected to generator.</li> <li>b) Defective receptacle.</li> <li>c) Generator overloaded.</li> </ul>	<ul style="list-style-type: none"> <li>a) Disconnect load.</li> <li>b) Replace receptacle.</li> <li>c) Reduce the load. (See Power Load Planning &amp; Mgt. Section of this manual.)</li> </ul>
Voltage too high.	<ul style="list-style-type: none"> <li>a) Engine speed too high.</li> </ul>	<ul style="list-style-type: none"> <li>a) Bring generator to a qualified technician for adjustment.</li> </ul>
Generator overheating.	<ul style="list-style-type: none"> <li>a) Generator is overloaded.</li> <li>b) Insufficient ventilation.</li> </ul>	<ul style="list-style-type: none"> <li>a) Reduce the load. (See Power Load Planning &amp; Mgt. Section of this manual.)</li> <li>b) Make sure there is at least 7 feet of clearance on all sides of generator.</li> </ul>
No output voltage.	<ul style="list-style-type: none"> <li>a) Defective load connected to generator.</li> <li>b) Broken or loose wire.</li> <li>c) Defective receptacle.</li> <li>d) Defective stator.</li> <li>e) Defective rotor.</li> <li>f) Defective capacitor.</li> <li>g) Circuit breaker tripped.</li> </ul>	<ul style="list-style-type: none"> <li>a) Disconnect load.</li> <li>b) Bring generator to a qualified technician for repair.</li> <li>c) Replace receptacle.</li> <li>d) Bring generator to a qualified technician for repair.</li> <li>e) Bring generator to a qualified technician for repair.</li> <li>f) Bring generator to a qualified technician for repair.</li> <li>g) Reset circuit breaker and reduce loads connected to the generator.</li> </ul>
Engine lacks power.	<ul style="list-style-type: none"> <li>a) Generator is overloaded.</li> <li>b) Dirty air filter.</li> </ul>	<ul style="list-style-type: none"> <li>a) Reduce the load. (See Power Load Planning &amp; Mgt. Section of this manual.)</li> <li>b) Clean or replace air filter.</li> </ul>

## Summary of Important Safety Information

This section provides a summary of the various safety procedures and measures that have been presented throughout the manual. Keep this summary handy and refer to it to refresh your memory about how to safely use your generator.

### WARNING

Carefully read and make sure you understand the following safety information before using the generator.

Improper use or maintenance of the generator can result in *serious injury or death* from *carbon monoxide poisoning, electric shock, entanglement, fire, or burns*. In addition, the generator *can lift or flip and cause severe injury* if improperly secured.

### General

- **Read manual.** Read this Owner's Manual and the engine Owner's Manual completely before attempting to set-up and use the generator. Serious injury or death can result if safety instructions are not followed.
- **Instruct operators.** The generator owner must instruct all operators in safe generator set-up and operation. Do not allow anyone to operate the generator who has not read the Owner's Manual and been instructed on its safe use.
- **Adults only.** Only trained adults should set up and operate the generator. Do not let children operate.
- **Under the influence.** Never operate, or let anyone else operate, the generator while under the influence of alcohol, drugs, or medication.
- **Intended use.** Carefully read about and understand the intended use of this generator. Do not use for other purposes, as unforeseen hazards or equipment damage may result.

### Prohibition Against Modifications

- **Modifications prohibited.** Never modify or alter the generator in any way. Modifications can create serious safety hazards and will also void the warranty.
- **Fuel/exhaust system.** Never modify the engine's exhaust system, fuel tank, or fuel lines. Carbon monoxide poisoning, fire, or explosion could result.
- **Guards.** Do not operate generator unless all guards and cover shields, which prevent access to moving parts and pinch points, are in place. Failure to guard the power transmission mechanisms *may result in serious injury or death*.

### Safety – Installation & Set-up

- **Mount generator and engine.** Failure to properly mount the generator may cause the unit to lift or flip during use, which could result in severe injury to the operator or bystanders, or cause damage to surrounding objects.
  - The generator and engine must be securely mounted to a common base such as a heavy-duty metal plate.
  - The mounting base must be of adequate size and strength to withstand operating torque and vibration without either flipping or experiencing stress failure.
  - See the "Installation / Initial Set-Up" section of this Owner's Manual for mounting requirements and instructions.
- **Power transmission guarding.** The power transmission assembly must be equipped with a guard that prevents contact with all rotating shafts, pulleys, belts, and couplings. Clothing or hair can become rapidly entangled in unguarded rotating parts, resulting in *serious injury or death*. This guard is not supplied with the unit because the generator manufacturer does not know the size and dimensions of the engine to be used. The customer is responsible for installing an appropriate guard.
- **Dry, level surface.** Situate generator on a dry, firm, level surface. Ensure generator sits level and will not slide or shift during operation.
- **DANGEROUS carbon monoxide exhaust - Operate OUTSIDE only!** The engine gives off carbon monoxide exhaust, a poisonous gas that can kill. You CANNOT smell it, see it, or taste it. ONLY run generator OUTDOORS and away from building air intakes. NEVER run generator inside homes, garages,

## Summary of Important Safety Information (cont'd)

barns, sheds, or other semi-enclosed spaces. These spaces can trap poisonous gases, EVEN if you run a fan or open windows.

- **Cooling ventilation.** The generator needs adequate, unobstructed flow of air to allow for proper cooling of engine and generator head so it does not overheat and possibly cause fire. Situate so there is adequate clearance around generator to allow for cooling airflow. Do not allow debris to accumulate and block airflow. Keep all objects at least 7 feet away from vent slots.
- **Grounding.** Always ensure generator is properly grounded to prevent electrical shock. This generator is equipped with a grounding screw. Always complete the grounding path from the generator to a copper pipe/rod driven into moist earth to a sufficient depth. Check with an electrician for local grounding requirements. If a licensed electrician installs the generator with a connection to your building's electrical circuit for use as a standby power system, grounding will be complete through the building's grounding system.
- **Isolate connection to building's electrical circuit.** Never plug the generator directly into a wall outlet. ANY connection to a building's electrical system MUST ISOLATE THE GENERATOR FROM UTILITY POWER via an UL-approved transfer switch installed by a licensed electrician in compliance with all applicable local building and electrical codes. If the generator is not isolated from the utility power system by such means, generator output will back feed into the utility power grid. This may result in injury or death to utility power workers or others who contact the lines during a power outage. It may also cause the generator to explode or cause fire when utility power is restored.
- **Wet conditions.** Water conducts electricity. Do not operate generator where it is wet. Operate on a dry surface under an open, canopy-like structure.
- **Hot engine exhaust.** Engine exhaust can be extremely hot and cause fire. Refer to your engine manual to determine safe clearance distance required between hot exhaust and nearby combustible objects.
- **Belt tension.** Belt slippage can cause static electricity build-up, which may result in sparking. Fire ignition can result. Follow instructions in this manual for adjusting belt tension.
- **CO alarms.** Ensure that working, battery-operated or battery back-up carbon monoxide alarms are used in any dwelling/structure that is in close proximity to the running generator.
- **Fire extinguisher.** Keep a fire extinguisher rated "ABC" by the National Fire Protection Association nearby. Keep it properly charged and be familiar with its use.

### Safety – Before Use

#### Know how to operate

- **Review safety rules.** Before each use of this generator, review the "Rules for Safe Operation." Failure to follow these rules may result in serious injury or death.
- **Know how to operate.** Be thoroughly familiar with all controls and with the proper use of the equipment. Know how to stop the generator quickly if needed.
- **Inspect.** Before each use, inspect the generator, engine, and power transmission assembly (belts, pulleys, couplings). Ensure generator/engine mounting is secure. Check for fuel leaks and loose or damaged parts. Do not operate the generator with damaged, missing, or broken parts.

#### Personal protective equipment

- **Hearing protection.** The use of ear plugs or other hearing protection device is recommended for those in close proximity to the generator while it is operating.
- **No loose / dangling apparel.** Loose or dangling apparel and long hair can become entangled in moving/rotating parts. Metal jewelry can conduct electricity. Never wear jewelry or loose-fitting clothing such as neckties, scarves, or long-sleeved or untucked shirts when operating the generator. Tie back hair and secure close to head.

#### Battery Safety

##### **(If engine is equipped with battery start)**

Batteries are hazardous because they contain caustic acid, can emit explosive gases, and can cause electric shock. *Caution must be exercised when making connections to a battery to avoid shock and contact with the acid, and to prevent any sparking that could lead to an explosion.* Follow safety rules carefully when connecting battery to engine:

- **Eye/skin protection.** Always wear eye protection and protective clothing when connecting or disconnecting battery.

## Summary of Important Safety Information (cont'd)

- **Sparks/Smoking.** Never smoke or work near sparks or other sources of ignition.
- **Electric shock.** Never touch both battery terminals at the same time with your hand or any non-insulated tools.
- **Connection/disconnection sequence.** ALWAYS connect and disconnect cables to the correct battery terminals in the proper sequence:
  - When CONNECTING the battery, connect the RED cable to the POSITIVE terminal FIRST.
  - When DISCONNECTING the battery, disconnect the BLACK cable from the NEGATIVE terminal FIRST.
- **Acid/skin contact.** If battery acid contacts skin or clothing, flush immediately with water and neutralize with baking soda.

### Gasoline safety - fueling your engine

Gasoline is highly flammable and explosive. You can be burned or seriously injured when handling fuel. Use extreme care when handling:

- **Fuel outdoors.** Fill fuel tank outdoors – never indoors. Gasoline vapors can ignite if they collect inside an enclosure. Explosion can result.
- **Use approved container.** Never pump fuel directly into engine at gas station. Static charge can build and ignite fuel. Use an UL approved fuel container to transfer gas to the engine.
- **Running / hot engine.** A running engine is hot enough to ignite fuel. Never add fuel or remove gas cap if engine is running or still hot. Stop the engine and allow to cool at least two minutes before adding fuel.
- **Heat / flames / sparks.** Stay away from sources of heat, flame, or sparks while adding fuel.
- **Don't overfill.** DO NOT overfill the gas tank. Allow at least 1/2" of empty space below the fill neck to allow for fuel expansion.
- **Replace cap.** Replace gas cap securely before starting engine.
- **Spills.** Clean up fuel spills immediately. Move generator away from spilled fuel on the ground. Wipe fuel off engine and wait 5 minutes for excess fuel to evaporate before starting engine. Gas soaked rags should be disposed of properly.
- **On skin / clothes.** If gasoline is spilled on your skin or clothes, change clothes and wash skin immediately.
- **Inspect fuel system.** Check fuel system on a regular basis. Look for signs of leaks, deterioration, or damaged fuel tank. Do not start engine until needed repairs have been completed.
- **Gasoline storage.** Store gasoline in a cool, dry place in an UL-approved, tightly sealed container.

### Safety – During Use

- **Safety equipment / controls.** Always operate the generator with all safety covers, guards, and barriers in place and in good working order, and all controls properly adjusted for safe operation.
- **Know how to stop.** Be thoroughly familiar with proper use of the equipment and all generator controls, output receptacles, and connections. Know how to stop the generator quickly if needed.
- **Power transmission guarding.** Never operate the generator without proper guarding of the power transmission assembly, including all rotating shafts, pulleys, belts, and couplings. Clothing or hair can become rapidly entangled in unguarded rotating parts, resulting in *serious injury or death*.
- **Check output voltage.** Check output voltage to ensure the generator is working properly before connecting loads to the generator. Failure to do so could result in damage to equipment powered by the generator and possible injury to the individual. Do not adjust output speed of engine to change voltage. If voltage is not within specified range, have generator repaired by factory authorized personnel.
- **Stabilize before connecting loads.** Start generator and let engine stabilize before connecting electrical loads.
- **Do not overload.** Do not overload the generator. Make sure that combined starting and running loads do not exceed rated capacity of generator or damage will result.
- **Protect sensitive electronics.** Some electronic equipment, such as computers and audio/video equipment, can be damaged by small fluctuations in the flow of power. Use a surge suppressor for any voltage-sensitive electronic equipment you will be powering with the generator.
- **Electrical cords.** Use only UL-listed, outdoor-rated, three prong extension cords of the proper size. All extension and appliance cords must be in good condition and not worn, bare, frayed, or otherwise damaged. Use of inadequate or damaged electric cords can cause electric shock or fire.
- **GFCI extension cords.** Always use ground fault circuit interrupter (GFCI)-equipped extension cords to prevent electrical shock in damp or highly electrical conductive areas and on construction jobsites.
- **Wet conditions.** Do not operate the generator or handle any electrical equipment while standing in water, while barefoot, while hands are wet or while in the rain or snow. Electric shock may result.
- **Avoid contact.** Avoid contact with bare wires, terminals, connections, etc. while the unit is running.

## Summary of Important Safety Information (cont'd)

- **Electric shock accident.** If an electric shock accident occurs, immediately shut down the source of electrical power. If this is not possible, attempt to free the victim from the live conductor. Avoid direct contact with victim. Use a nonconducting implement, such as a dry rope or board, to free the victim from the live conductor. Apply first aid and get immediate medical help.
- **Hot parts.** Parts of the engine and generator are extremely hot during and after operation and can burn you. Never touch hot muffler, hot exhaust manifold or any other part of the engine or generator unless you have first determined if it is hot. Wait a sufficient time for parts to cool before touching any part of the generator or engine.
- **Moving parts.** Keep hands, feet, and apparel away from drive belts, sheaves, couplings, fans, and other moving parts. Never attempt to remove any guard or shield while the unit is operating.
- **Smoking/sparks.** Never smoke near the running generator, and never operate near sources of sparks or flames.
- **Carbon monoxide poisoning.** The engine gives off carbon monoxide, a poisonous gas that can kill you. You CANNOT smell it, see it, or taste it. If you start to feel sick, dizzy, or weak while using the generator, shut off the engine and get to fresh air RIGHT AWAY. See a doctor. You may have carbon monoxide poisoning.
- **Malfunction during operation.** Immediately turn off the generator if any of the following conditions arise during operation:
  - Excessive change in engine speed, slow or fast
  - Overheating in load connecting devices
  - Sparking or arcs from generator
  - Loss of electrical output
  - Receptacle damage
  - Engine misfire
  - Excessive vibration
  - Flame or smoke
  - Abnormal noise
- **Adjusting / repairing.** Before working on the generator or engine, always turn off engine and remove spark plug(s) or spark plug wire(s) to prevent accidental starting.

### Safety – After use

- **Cool before storing.** Let engine and generator cool for at least five minutes before storing. Hot equipment can be a fire hazard near combustible materials.
- **Prevent accidental starting.** When generator is not in use, remove key from engine starter (key start engines) and secure in a safe location, or remove spark plug(s) or spark plug wires(s) in order to ensure that generator cannot be started in a storage location or by untrained persons.
- **Storage location.** Store the generator/engine assembly in a dry location away from sources of heat, open flames, sparks or pilot lights – such as water heaters, space heaters, furnaces, clothes dryers, or other gas appliances – EVEN IF the engine's gas tank is empty. Residual gasoline could ignite.
- **Exercise regularly.** Exercise generator every four weeks to dry out moisture that accumulates in the windings. If generator cannot be exercised on a regular basis, prepare generator for long term storage.
- **Periodic maintenance.** Perform periodic maintenance as directed in this manual to keep the generator in safe working condition.

### Safety - Inspection/Maintenance

Inspect and maintain your generator on a regular basis and repair as needed to keep it in safe working condition:

- **Turn off engine.** Always turn off engine and remove spark plug(s) or spark plug wire(s) before working on the engine or generator to prevent accidental starting.
- **Discharge capacitor.** When the generator is shut down, the capacitor may maintain a charge. Always discharge the capacitor before working on the generator head to prevent electrical shock.
- **Clear debris/deposits.** Keep generator head and moving parts clean. This will ensure the generator is in safe working condition.
- **Replace guards / shields.** Make sure all guards and shields are replaced after servicing the generator.
- **Replacement parts.** If a part needs replacement, only use parts that meet the manufacturer's specifications. Replacement parts that do not meet specifications may result in a safety hazard or poor operation of the generator and will void the warranty.

# Exploded View – 165913H.2

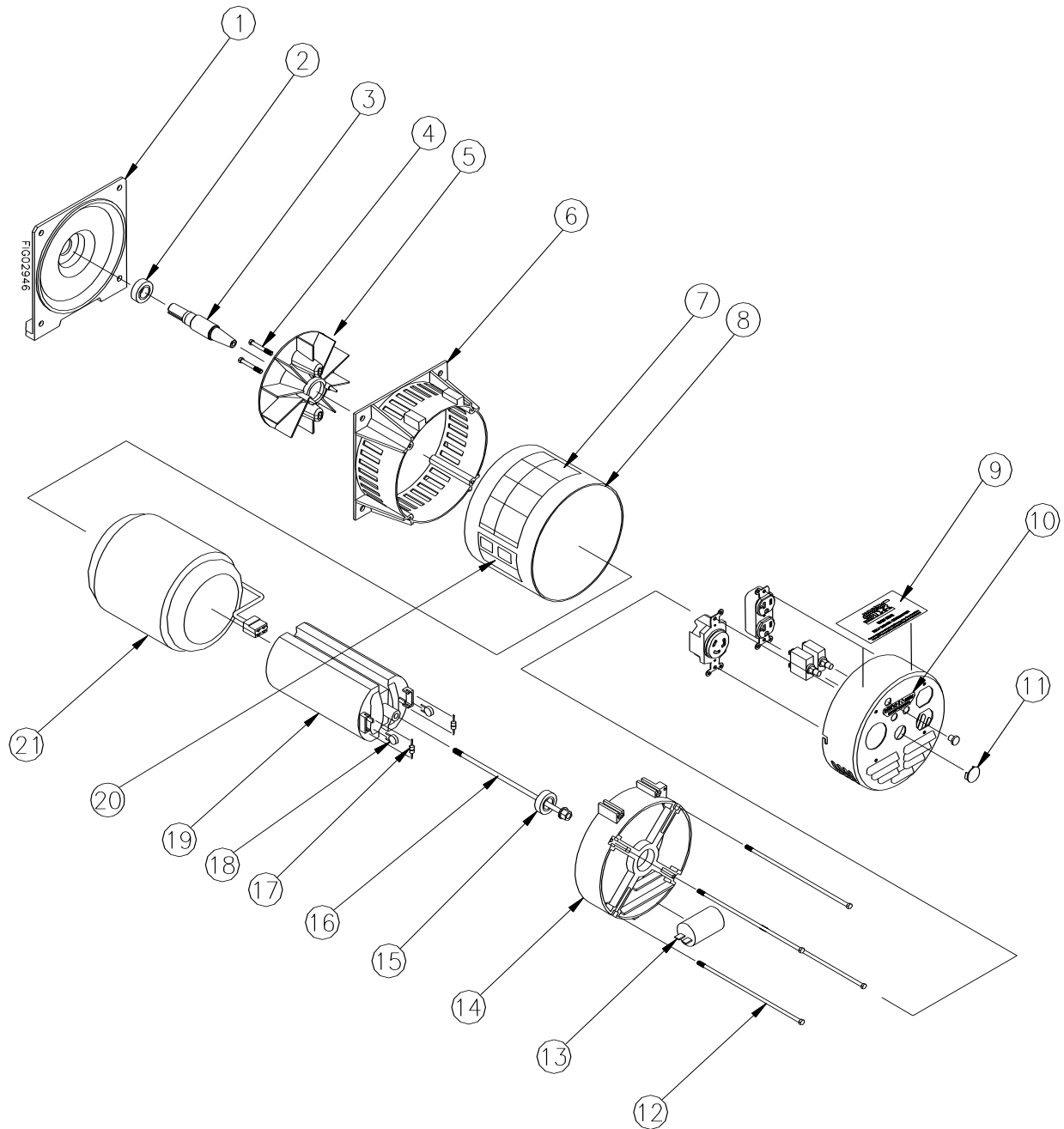

Diag #	Part #	Description	Qty
1	779579	Bearing Mount Plate	1
2	306403	Stub Shaft Bearing	1
3	3055252	Stub Shaft	1
4	306404	Fan Bolts	2
5	778953	Fan	1
6	306406	Drive End Bracket	1
7	780342	General Warning Decal	1
8	778954	Enclosing Band	1
9	780247	5500 BDG Decal	1
10	306576	Circuit Breaker Decal	1
11	306408	End Cover Plug	1

Diag #	Part #	Description	Qty
12	778960	Bracket Securing Stud	4
13	778958	Capacitor	1
14	306417	Non Drive End Bracket	1
15	307485	Bearing	1
16	778957	Securing Stud & Nut	1
17	778959	Diode	2
18	778961	Varistor	2
19	778956	Rotor	1
20	307494	Nameplate	1
21	778955	Stator	1



# Wiring Diagram – 165913H.2

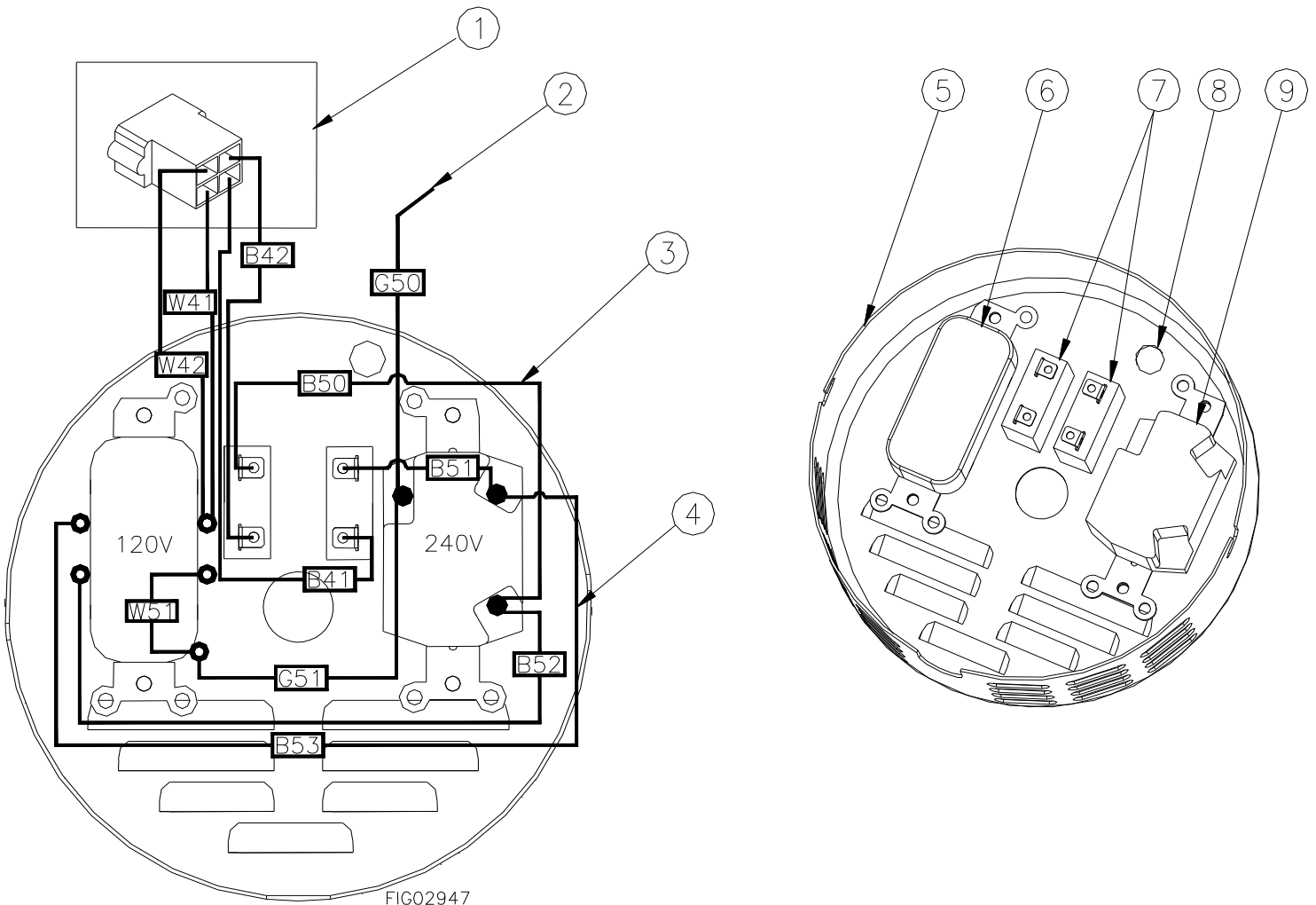

Diag #	Part #	Description	Qty
1	306495	Connector Wire Harness	1
2	306582	Wire Assembly (W51, G50, G51)	1
3	306583	Wire Assembly (B50, B52)	1
4	306584	Wire Assembly (B51, B53)	1
5	305553	End Cover	1
6	31736	120V 20A Duplex Receptacle (NEMA 5-20R)	1
7	30643	20A Circuit Breaker	2
8	30815	5500 BDG Plug	1
9	306427	240V 20A Locking Receptacle (NEMA L6-20R)	1

*This page has intentionally been left blank.*

# Limited Warranty

Dear Valued Customer:

The NorthStar Product you just purchased is built with the finest material and craftsmanship. Use this product properly and enjoy the benefits from its high performance. By purchasing a NorthStar product, you show a desire for quality and durability. Like all mechanical equipment this unit requires a due amount of care. Treat this unit like the high quality piece of machinery it is. Neglect and improper handling may impair its performance. Please thoroughly read the instructions and understand the operation before using your product. Always contact NorthStar Product Support at 1-800-270-0810 prior to having any service or warranty work performed, as some services performed by parties other than NorthStar approved service centers may void this warranty. This warranty is in lieu of any other warranty expressed or implied and NorthStar assumes no other responsibility or liability outside that expressed within this warranty.

## Limited Warranty

NorthStar shall warranty any piece of equipment manufactured, or parts of equipment manufactured, to be free from defects in material or workmanship for a period of:

<b>NorthStar Warranty</b>		
<b>Item #</b>	<b>Consumer Warranty Period</b>	<b>Commercial Warranty Period</b>
165913	1 year from date of purchase by user	1 year from date of purchase by user

“Consumer use” means personal residential household and/or recreational use by a consumer. “Commercial use” means all other uses, including use for commercial, income producing, primary power, off grid power, or rental purposes or when purchased by a business.

This warranty applies to the original purchaser of the equipment (verification of purchase, in the form of a receipt, is the responsibility of the buyer), is non-transferable, and covers parts and labor. Parts will be replaced or repaired at no charge, except when the equipment has failed due to lack of proper maintenance. If a part is no longer available, the part may be replaced with a similar part of equal function. Any misuse, abuse, alteration or improper installation or operations will void warranty. Determining whether a part is to be replaced or repaired is the sole decision of NorthStar. NorthStar will not provide for replacement of complete products due to defective parts. Any costs incurred due to replacement or repair of items outside of a NorthStar approved facility is the responsibility of the buyer and not covered under warranty. Transportation costs to and from service center is the responsibility of the customer.

This warranty specifically excludes the following; failure of parts due to damage caused by accident, fire, flood, windstorm, acts of God, applications not approved by NorthStar in writing, corrosion caused by chemicals, use of replacement parts which do not conform to manufacturer’s specifications, damage to accessory parts such as starting batteries, damage related to rodent and/or insect infestation and damage caused by vandalism. Additional exclusions: loss of running time, inconvenience, loss of income, or loss of use, including any implied warranty of merchantability of fitness for a specific use. Also, Outdoor Power Equipment needs periodic parts and service to perform well, and this warranty does not cover instances when normal use has exhausted the life of a component or the engine.

This warranty does not cover any personal injury or damage to surrounding property caused by failure of any part. Repair or replacement of parts does not extend the warranty period.

Please fill in the following information and have it on hand when you call in on a warranty claim.

Customer Number: \_\_\_\_\_

Date of Purchase: \_\_\_\_\_

NorthStar Serial Number: \_\_\_\_\_

Item Number: \_\_\_\_\_



Manufactured by  
Northern Tool + Equipment Co.,  
2800 SouthCross Drive West  
P.O. Box 1499 Burnsville, MN 55337-0499